



FLOWSEAL

Marine Products



Flowseal high performance butterfly valves are available in sizes 2" through 48" in ASME pressure classes 150, 300 and 600 and with a diverse range of actuation options.

Flowseal is a leading provider of soft seat, metal seat and fire-safe high performance butterfly valves. Our products are manufactured under an ISO 9001 Quality Assurance Program that ensures each valve meets or exceeds your application requirements.

Flowseal high performance butterfly valves are a standard in many industries including heating, ventilation and air conditioning; power generation; hydrocarbon processing; water and waste water treatment; chemical processing and marine and commercial shipbuilding. Our products are also installed in applications as diverse as food and beverage processing, snowmaking and pulp and paper production. Configurations are available for harsh conditions as well as applications requiring nominal pressure and temperature ratings.

As part of Crane Valve Group, Flowseal high performance butterfly valves are backed by the resources and experience of one of the world's largest valve producers with a delivery and quality track record that is unparalleled in the industries we serve.

PRODUCT LINE

High Performance Butterfly Valves

- Soft Seat Design
- Metal Seat Design
- Fire-Safe Seat Design
- ISO Design
- Marine Design
- Nuclear Power Design

Pneumatic Actuators

- Series 43000 Spring Return Actuator
- Series 48000 Double Acting Actuator

Electric Actuators

- Series 44000

Manual Operators

- Series W Gear Operators
- Levers

The Flowseal Fire-Flow™ valve uses the same Soft Seat for bidirectional shut-off, but also features a patented metal seat to seal against the disc after a fire. With little to no pressure, the spring force and hoop load of the metal seat provides metal to metal seating.

Higher line pressures act on the geometry of the seat to load it against the disc, creating higher sealing forces in either direction.

The Fire-Flow seat is made of 300 Series Stainless or Inconel 718 (annealed) sheet which is hydroformed into the unique seat configuration. Stainless steel outer bearings and high temperature packing is also included in the Fire-Flow design to meet and exceed the requirements of industry "fire-safe" specifications.

WEDGE RING

Stainless steel band wedged between valve body and retainer ring by set screws to lock seat and retainer ring in position.

DISC SPACERS

Disc is centered by use of thrust spacers around shaft in sizes 2½" to 4", and disc position stops in body on larger sizes.

SET SCREWS

Cone point screws force wedge ring outward to lock seat retainer in position.

OVERTRAVEL STOP

Prevents disc from rotating into wrong quadrant.

RETAINER RING

Retains seat in valve. Standard surface finish is 125 to 200 AARH and is compatible with both standard gaskets and spiral wound gasket designs. Outside diameter is recessed within gasket sealing surface to prevent external leakage.

FIRE-FLOW SEAT

Patented bi-directional soft seat design for zero-leakage in normal operation and a metal-to-metal seal after fire, meeting or exceeding industry "fire-safe" specifications.

SHAFT

Solid shaft provides alignment and rigid support for disc.

KEY

Square key valve-to-operator connection provides an externally controlled failure point upon over-torquing.

GLAND FLANGE

Applies load against packing gland to prevent external leakage. Fully adjustable.

PACKING GLAND

Separate part from gland flange, preventing uneven load distribution against packing.

PACKING

Common materials are asbestos graphite.

OUTER BEARINGS

Stainless steel back-up bearings maintain shaft alignment after a fire. (Both above and below disc.)

INNER BEARINGS

Both above and below the disc, bearings are of composite design: PTFE bonded to epoxy-glass filament wound ring. Used to align shaft, with high load capacity, low wear and low friction coefficient.

WEDGE PINS

Provide positive mechanical attachment of disc to shaft.

DISC

Fire-Flow disc is electroless nickel plated for enhanced temperature and abrasion resistance.

BODY

ASME B16.34 design in either wafer or lug configuration.

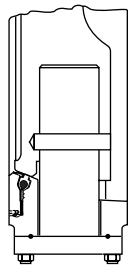

End Seal Variation

The ASME 150 16" through 24" sizes feature a two-piece shaft design. The lower shaft utilizes an end seal in the body to prevent external leakage. The component parts include an end seal, an end cap and end cap bolts.

Lower Packing Variation

The ASME 150 30" through 48"; ASME 300 14" through 30"; ASME 600 10" through 14" sizes feature a two-piece shaft design which utilizes a lower packing seal in the valve body to prevent external leakage. The component parts are of the same design used in the packing assembly in the top of the valve body neck.

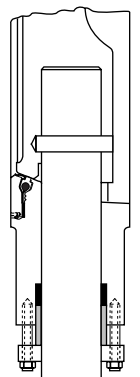

Flowseal is an approved supplier of High Performance Butterfly Valves in accordance with Military Specification MIL-V-24624 (SH).

The factory in Long Beach, California has been surveyed for conformance to the MIL-I-45208 Quality Inspection System. The product has undergone rigorous testing for design, cycle life, fire, shock & vibration and zero leakage. Having successfully passed these requirements, the Department of the Navy, Naval Sea Systems Command, has placed Flowseal on their Qualified Products List QPL-24624-4.

Flowseal is also listed on the Federal Supplier Code Specification FSC 4820, and is assigned Federal Supplier Code for Manufacturers (FSCM) #67266.

Qualified Products List QPL – 24624-4

Style A	Wafer (flangeless) Body
Style B	Lug (single flange) Body
Type I	Corrosion Resistant Steel, Synthetic Seated, Fire Resistant
Type III	Non-ferrous, Synthetic Seated, Fire Resistant
Sizes:	2 1/2", 3", 3 1/2", 4", 5", 6", 8", 10", 14"

- CID/APL and NSN numbers available on request
- Provisioning Technical Documentation available on request

Flowseal MIL-V-24624 Figure # Cross-Reference

Style A Type I	=	Flowseal Figure 1WA-291FGF-3MG
Style A Type III	=	Flowseal Figure 1WA-5X3XGF-3MG
Style B Type I	=	Flowseal Figure 1LA-291FGF-3MG
Style B Type III	=	Flowseal Figure 1LA-5X3XGF-3MG

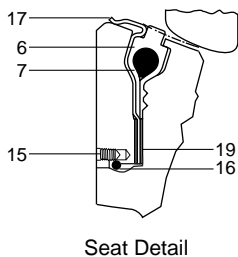
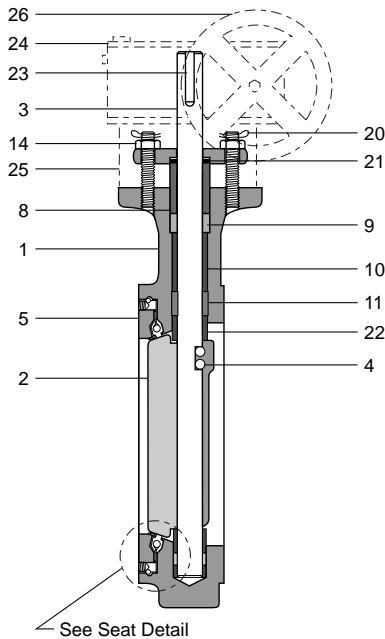

Flowseal MIL-V-24624 (SH) Standard Bill of Materials

Item #	Part Description	Type I Materials	Type III Materials
		Flowseal Fig. # 1WA-291FGF-3MG # 1LA-291FGF-3MG	Flowseal Fig. #1WA-5X3XGF-3MG #1LA-5X3XGF-MG
1	Body	ASTM A182-F316/A351-CF8M	Aluminum Bronze MIL-B-24480
2	Disc	ASTM A182-F316/ENP	Monel QQ-N-288 Comp. A/ENP
		ASTM A351-CF8M/ENP	Monel QQ-N-281 Class A Form 2/ENP
3	Shaft	ASTM A564-630	Monel-QQ-N-286
4	Disc Wedge Pin	ASTM A564-630	Monel-QQ-N-286
5	Seat Retainer	ASTM A240-316	Aluminum Bronze MIL-B-24480
6	Soft Seat	PTFE	PTFE
7	O-ring	Silicone AMS 3357 or equal	Silicone AMS 3357 or equal
8	Gland	18-8 Stainless Steel	Monel QQ-N-261
9	Packing	Graphite Rings & Graphite Rope	Graphite Rings & Graphite Rope
10	Outer Bearing	18-8 Stainless Steel	Monel QQ-N-281
11	Inner Bearing	Glass Backed PTFE	Glass Backed PTFE
12	Gland Follower	18-8 Stainless Steel	18-8 Stainless Steel
13	Gland Stud	18-8 Stainless Steel	18-8 Stainless Steel
14	Gland Stud Nut	18-8 Stainless Steel	18-8 Stainless Steel
15	Lock Screw	18-8 Stainless Steel	18-8 Stainless Steel
16	Wedge Ring	18-8 Stainless Steel	18-8 Stainless Steel
17	Metal Seat	18-8 Stainless Steel	Monel ASTM B127
18	Tag (not shown)	Stainless Steel	Stainless Steel
19	Metal Seat Gasket	Graphite	Graphite
20	Cotter Key	18-8 Stainless Steel	18-8 Stainless Steel
21	Snap Ring	Beryllium Copper CDA #172	Beryllium Copper CDA #172
22	Disc Spacer	18-8 Stainless Steel	Monel QQ-N-281 (2.5" to 5")
23	Key	Carbon Steel	Carbon Steel
24	Gear	Ductile Iron	Al. Brz. MIL 3-Duragear Dwg #3-1039
25	Mounting Bracket	18-8 Stainless Steel	Al. Brz. MIL-B-24480
26	Handwheel	Aluminum	Aluminum
		NAVSHIPS Dwg #803-1385620	NAVSHIPS Dwg. #803-1385620
27	Hex Head Capscrew	18-8 Stainless Steel	18-8 Stainless Steel
28	Hex Head Capscrew	18-8 Stainless Steel	18-8 Stainless Steel

DISC OPEN, Normal Operation

In Figure 1, the disc and seat assembly are not engaged. In this position, the metal seat acts to keep the soft seat inside the seat cavity while the soft seat shoulders seal the cavity from exposure to the process fluid. (The o-ring is under tension and imparts a load against the soft seat.)

The soft seat is protected from abrasion and wear because it is recessed inside the seat cavity area. The o-ring is isolated from exposure to the fluid because it is completely encapsulated by the seat tails which act as a (soft) gasket in the anchoring groove area. The metal seat gaskets add further high temperature protection past the anchoring grooves.

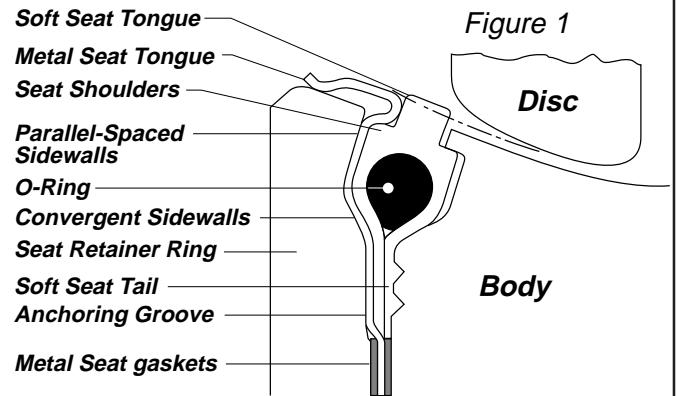

DISC CLOSED, Normal Operation

In Figure 2, the disc and seat assembly are engaged; both the metal seat and the soft seat are in contact with the disc. Under little to no pressure conditions, the metal and soft seats are self-energized. The disc edge, with a larger diameter than the seat tongues, moves the seats radially outward; the metal seat shape, with a mechanical and dynamic flexibility, is designed to be hoop-loaded and impart a spring force against the disc, while the soft seat o-ring is stretched and flattened (without deformation of the thermoplastic material) and imparts a mechanical pre-load against the disc.

With increased line pressure, the process fluid enters the cavity sidewall area and applies loads against the seat sidewalls. The cavity design permits the seats to move toward the downstream sidewalls, but confines and directs the movement radially inward towards the disc; the higher the pressure the tighter the seal between the disc and seats. The symmetrical shape and angle of the cavity permit the seal to be bi-directional.

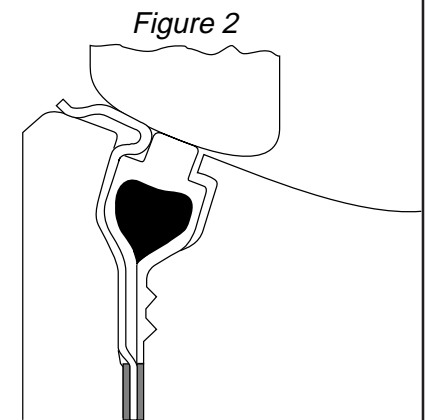

DISC CLOSED, After Fire (Seat Upstream)

After a fire, with partial or complete destruction of the soft seat, the metal seat maintains metal-to-metal contact with the disc and restricts leakage of the process fluid in conformance to industry fire-safe requirements.

With little or no line pressure, the spring force and hoop load of the metal seat maintain a "line contact" seal against the disc edge. Under higher pressures, the process fluid enters the cavity sidewall areas and applies loads against the seat sidewalls (Figure 3). The geometry of the metal seat permits the seat to move axially, but directs the movement radially inward toward the disc; The higher the pressure, the tighter the line contact seal.

Graphite gaskets, on both sides of the metal seat tail, seal the anchoring groove and prevent leakage of the process fluid.

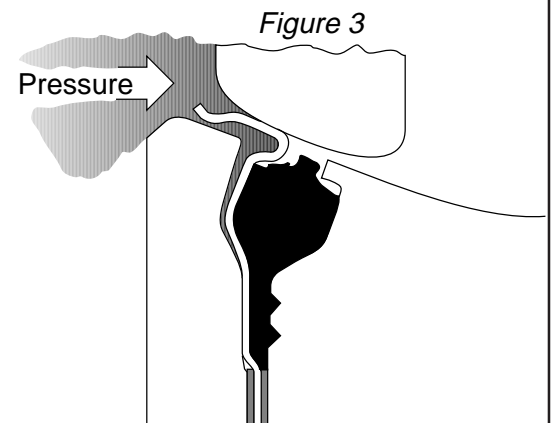

DISC CLOSED, After Fire (Seat Downstream)

The Flowseal Fire-Flow™ valve is bi-directional, however, modifications are required to operate for bi-directional dead end service. The angle and shape of the cavity and metal seat maintains metal-to-metal contact in the event of partial or complete soft seat destruction with line pressure in the reverse direction (Figure 4).

While the preferred flow direction is "seat upstream" (SUS), the bi-directional seat design is both self-energized and pressure-energized if the flow direction is "seat downstream" (SDS).

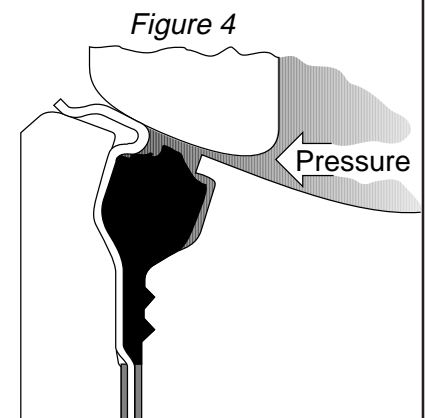

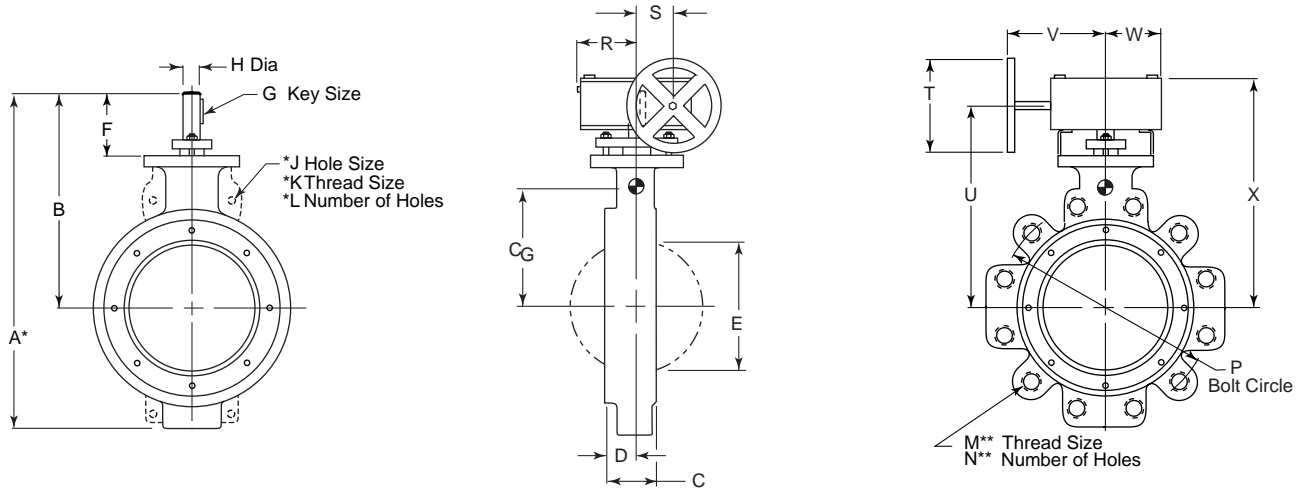

Valve Size	ASME Class	A	B	C	D	E	F	G	H	J*	K*	L*	M**	N**	P**	R	S	T	U	V	W	X	⊕ C _G	C _V
2.5	150	10.30	7.59	1.88	1.09	2.14	3.34	3/16	.500	-	-	-	-	-	-	2.5	2.5	.0	8.0	6.6	2.3	9.3	5.1	145
3"	150	11.60	8.60	1.88	1.21	2.86	3.60	3/16	.625	-	-	-	3/8 - 11	4	6.00	2.5	2.5	8.0	8.8	6.5	2.3	10.1	5.2	228
	300	11.60	8.60	1.88	1.21	2.88	3.50	3/16	.625	-	-	-	3/4 - 10	6	6.625	-	-	-	-	-	-	-	-	212
3.5"	150	11.98	6.72	2.06	1.30	3.25	3.60	3/16	.625	-	-	-	-	-	-	2.5	2.5	8.0	8.9	6.6	2.3	10.4	5.0	325
4"	150	12.92	9.42	2.13	1.26	3.70	3.67	3/16	.625	-	-	-	3/8 - 11	8	7.50	2.5	2.5	8.0	9.5	6.6	2.3	10.8	4.9	451
	300	12.92	9.42	2.13	1.25	3.70	3.67	3/16	.625	-	-	-	3/4 - 10	8	7.875	-	-	-	-	-	-	-	-	414
5"	150	14.53	10.28	2.25	1.34	4.59	3.81	1/4	.750	-	-	-	-	-	-	2.5	2.5	8.0	10.3	6.6	2.3	11.7	4.2	710
6"	150	15.69	10.81	2.25	1.38	5.61	3.81	1/4	.750	-	-	-	3/4 - 10	8	9.50	2.5	2.5	8.0	11.2	6.6	2.3	12.6	4.1	1103
	300	15.69	10.81	2.31	1.38	5.57	3.81	5/8	1.000	-	-	-	3/4 - 10	12	10.625	-	-	-	-	-	-	-	-	992
8"	150	17.81	11.94	2.50	1.49	7.32	3.81	5/8	1.000	-	-	-	3/4 - 10	8	11.75	2.5	2.5	10.0	11.9	6.6	2.3	13.7	5.2	2064
	300	18.09	12.22	2.88	1.54	7.12	4.09	5/8	1.250	-	-	-	7/8 - 9	12	13.00	-	-	-	-	-	-	-	-	1820
10"	150	19.55	12.97	2.81	1.70	9.25	4.09	5/8	1.250	oval	-	2	7/8 - 9	12	14.25	3.3	2.5	18.0	13.2	9.0	3.0	14.8	4.3	3517
	300	21.41	14.22	3.25	1.70	9.00	4.84	5/8	1.500	-	1-8	2	1 - 8	16	15.25	-	-	-	-	-	-	-	-	3042
12"	150	24.89	15.47	3.18	1.86	11.00	4.84	1/2	2.000	oval	-	4	1 - 8	12	17.00	3.5	3.3	18.0	14.7	9.0	3.5	16.8	4.7	4837
	300	28.28	17.90	3.62	1.86	10.77	6.90	3/8	1.750	-	1 1/8 - 8	4	1 1/8 - 8	136	17.75	-	-	-	-	-	-	-	-	4217
14"	150	26.59	16.09	3.62	2.19	12.09	4.64	1/2	1.500	oval	-	4	1 - 8	12	16.75	3.5	3.3	16.0	15.4	9.0	3.5	17.4	3.3	6530
	300	34.91	20.03	4.62	2.48	12.12	7.55	1/2	2.000	-	1 1/8 - 8	4	1 1/8 - 8	20	20.25	-	-	-	-	-	-	-	-	5430
16"	150	31.64	19.59	4.00	2.31	14.61	6.90	3/4	1.750	oval	-	4	1 - 8	16	21.25	-	-	-	-	-	-	-	-	8845
	300	38.32	21.82	5.25	2.59	13.77	7.82	1/2	2.250	-	1 1/4 - 8	4	1 1/4 - 8	20	22.50	-	-	-	-	-	-	-	-	7250
18"	150	34.54	21.36	4.50	2.45	16.41	7.36	3/4	2.000	thru	-	4	1 1/8 - 8	10	22.75	-	-	-	-	-	-	-	-	11400
	300	40.64	23.07	5.88	3.03	15.61	7.89	3/4	2.500	-	1 1/4 - 8	4	1 1/4 - 8	24	24.75	-	-	-	-	-	-	-	-	9250
20"	150	36.70	22.76	5.00	2.94	16.42	7.63	3/4	2.250	-	1 1/8 - 8	4	1 1/8 - 8	20	25.00	-	-	-	-	-	-	-	-	13800
	300	44.01	25.13	6.31	3.25	17.26	8.75	3/4	3.000	-	1 1/4 - 8	4	1 1/4 - 8	24	27.00	-	-	-	-	-	-	-	-	10500
24"	150	41.31	25.13	6.06	3.12	21.91	7.88	3/4	2.500	-	1 1/4 - 8	4	1 1/4 - 8	20	20.50	-	-	-	-	-	-	-	-	21000
	300	49.89	28.01	7.19	3.62	20.51	8.53	1	3.500	-	1 1/2 - 8	4	1 1/2 - 8	24	32.00	-	-	-	-	-	-	-	-	15100

Dimension information for ASME Class 150, 30" to 48"; ASME Class 300 30" to 36"; ASME Class 600, 3" to 4" are available upon request.

ASME B16.34 Body and Flowseal Soft Seat Pressure - Temperature Ratings

As temperature increases, the pressure retaining capability of materials decreases. The graph below illustrates the pressure/temperature ratings of the Flowseal ASME Class 150, Class 300 and Class 600.

The heavy lines define the ratings of the carbon steel and stainless steel valve body (or "shell") in conformance to ASME B16.34. The shaded areas define the ratings of the soft seat.

Seat ratings are based on differential pressure with the disc in the fully closed position.

ASME B16.34 Body and Flowseal Soft Seat Pressure - Temperature Ratings

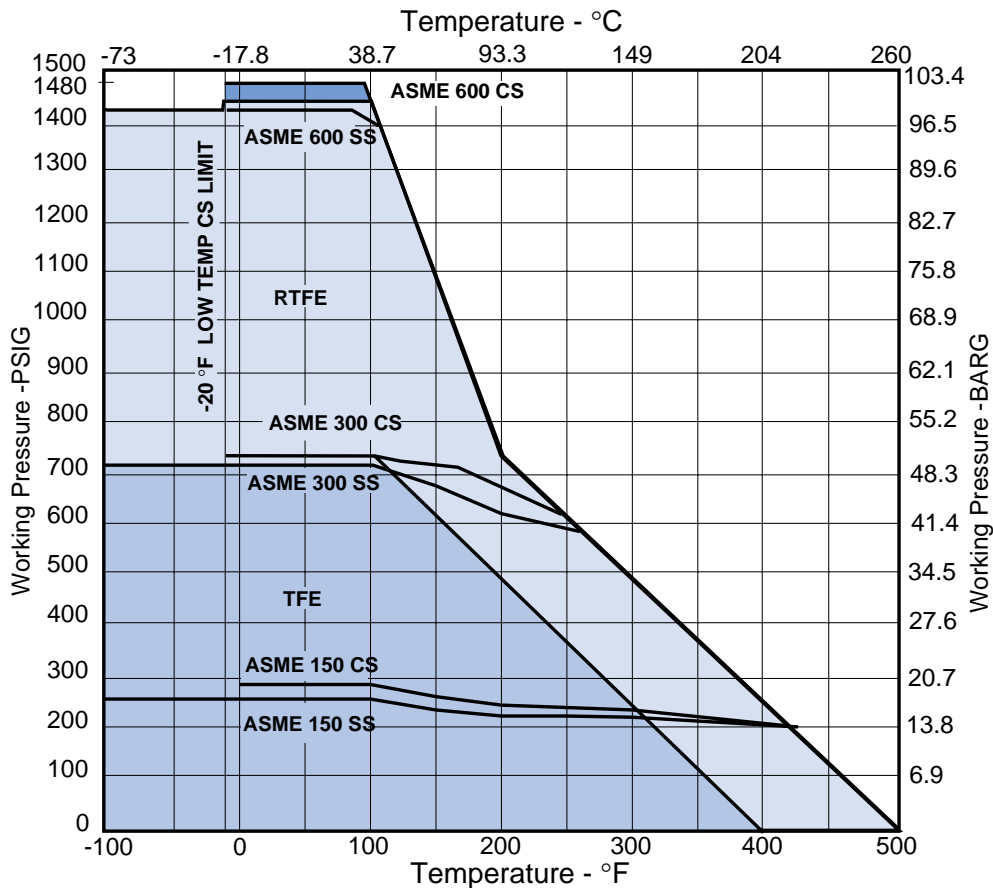
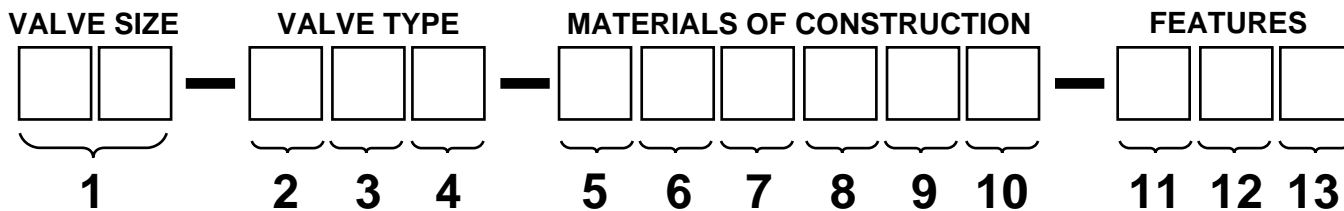

Figure Number System



1. Size Code
025 = 2 1/2"
03 = 3"
04 = 4"
to
48 = 48"

2. Body Class Code
1 = 150 ASME
3 = 300 ASME
6 = 600 ASME

3. Body Type Code
W = Wafer
L = Lug

4. Shaft Design Code
A = Straight
3"-24" ASME 150
3"-12" ASME 300
3"-8" ASME 600
C = Balanced
30"-48" ASME 150
14"-36" ASME 300
10"-14" ASME 600

5. Body Material Code
1 = Carbon Steel
2 = 316 SS
3 = Monel
4 = Alloy 20
5 = Alum Bronze
6 = Carbon Steel-ENP
7 = 316 SS Malcomized
9 = 316 SS-ENP
X = Special

6. Disc Material Code
2 = 316 SS
3 = Monel
4 = Alloy 20
5 = Alum Bronze
6 = Carbon Steel-ENP
7 = 316 SS Malcomized
9 = 316 SS-ENP
X = Special

7. Shaft Material Code
1 = 17-4PH SS
2 = 316 SS (Note1)
3 = Monel
4 = Alloy 20
6 = Inconel 718/x750
0 = Nitronic 50
X = Special

8. Seal Material Code
T = PTFE
R = RTFE
L = Polyethylene (UHMWPE)
F = Fire-Flow PTFE/300SS
B = Fire-Flow RTFE/300SS
M = Monel
S = 300 SS
X = Special Seat or O-ring

9. Packing Material Code
T = PTFE
G = Graphite
F = Fire-Flow
X = Special

10. Bearing Material Code
G = Glass backed PTFE
H = 316 SS backed PTFE
F = Fire-Flow (Garfil & 316 SS)
M = CS Nitrided
X = Special
B = Bronze
X = Special

11. Actuator Type Code
B = Bare Shaft
H = Ratchet Handle
L = Ratchet Handle w/Lock
2 = Worm Gear (Low Pressure)
3 = Worm Gear
4 = Pneumatic Double Acting
5 = Pneumatic SR Fail Close
6 = Pneumatic SR Fail Open
7 = Hydraulic
8 = Electric
X = Other

12. Special Feature Code
O = None
A = Oxygen Service
C = Chlorine Service
F = Flat Face
M = MIL-V-24624 (Note 2)
N = NACE Construction
S = 60 to 125 AARH Facing
V = Vacuum Service
X = Special Feature
Further Description Required

12. Series Code
**Factory Assigned

Example Part Number:

06-1WA-533TTG-HO

6" ASME Class 150, Wafer Type, Alum Bronze Body, Monel disc, Monel Shaft, PTFE Seat, PTFE Packing, Glass-back PTFE Bearings, with Lever Operator. No Special Features

Visit www.cranevalvelit.com
for on-line catalogs

Flowseal
9860 Johnson Road
Montgomery, TX 77316
936-588-8380
Fax 936-588-8381